

# ALTEA

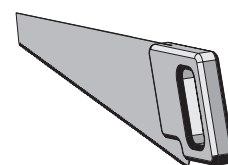
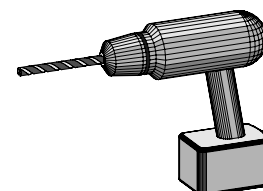
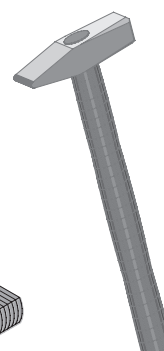
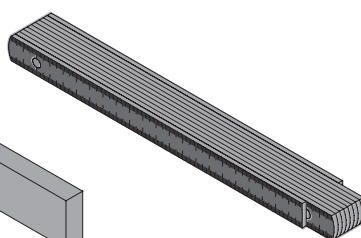
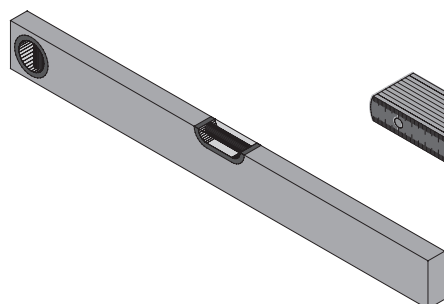
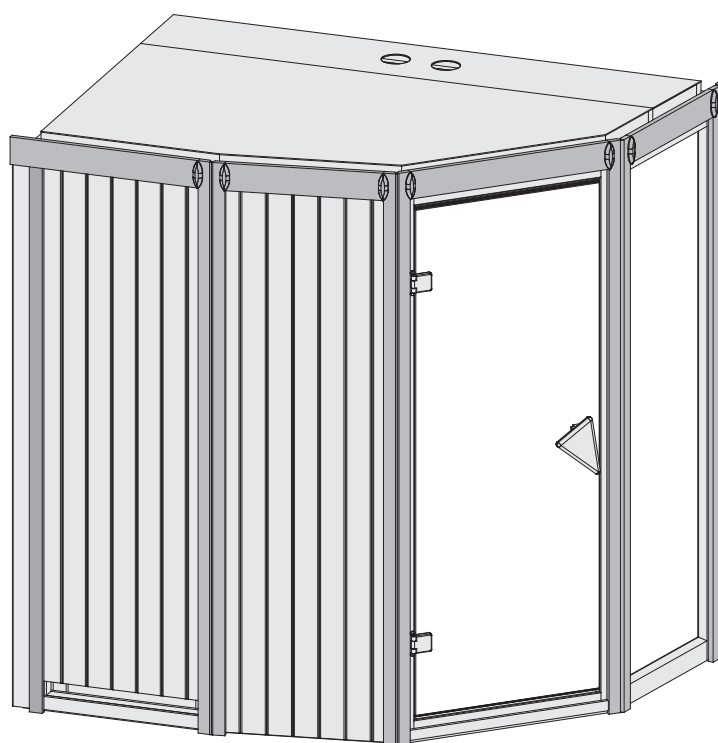

 **Aufbauanleitung**

 **notice de montage**

 **Building Instructions**

 **montagehandleiding**

 **Instrucciones de construcción**

 **Istruzioni per il montaggio**



Vergleichen Sie zuerst die Materialliste mit Ihrem Paketinhalt! Bitte haben Sie Verständnis, dass Beanstandungen nur im nicht aufgebauten Zustand bearbeitet werden können!



Commencez par comparer la liste du matériel avec le contenu de votre paquet! Sachez que nous traitons uniquement les réclamations concernant le matériel à l'état non monté!



First compare the list of materials with your package contents! Please understand that complaints can be processed in the non-built status only!



Vergelijk eerst de lijst van materialen met de inhoud van uw pakket! Reclamaties kunnen alleen in behandeling worden genomen zolang de onderdelen nog niet zijn gemonteerd!



En primer lugar, compare la lista de material con el contenido del paquete. Rogamos entienda que las reclamaciones sólo pueden ser tramitadas antes de montar el objeto!



Confrontate questa distinta materiali prima con il contenuto del pacchetto! Vi preghiamo di comprendere che eventuali reclami possono essere accolti solo prima del montaggio!



**59606**

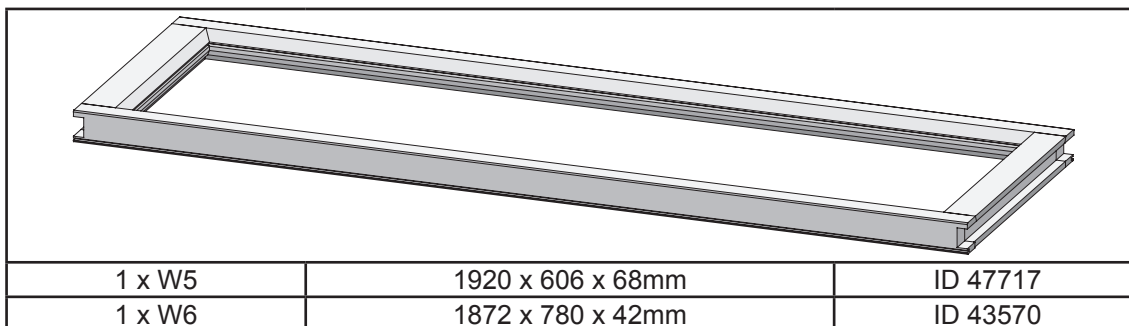
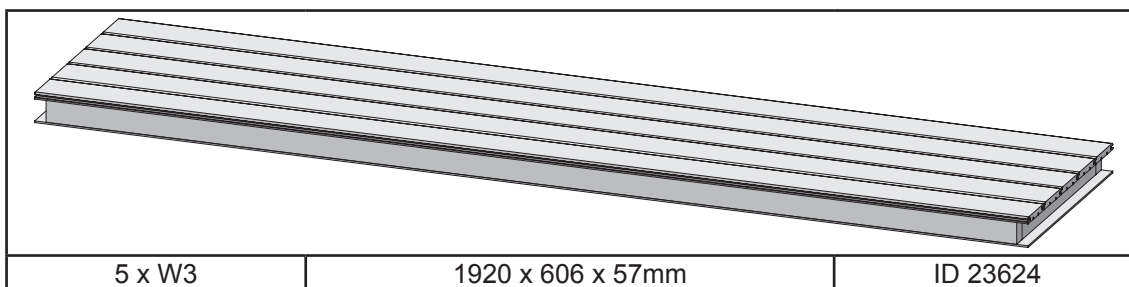
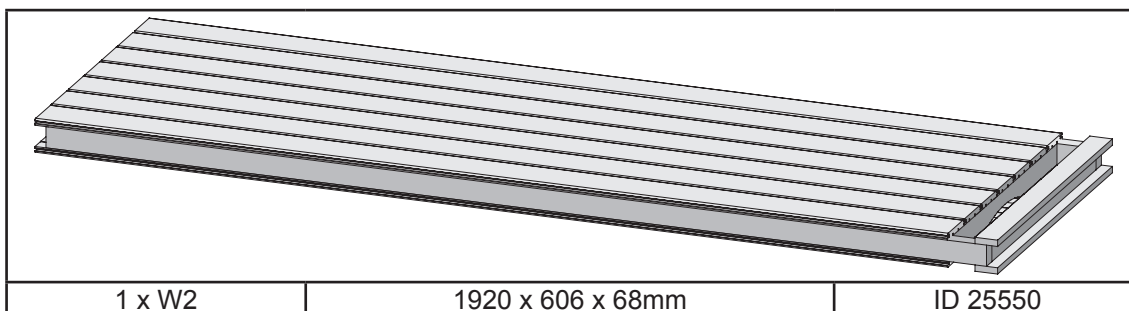
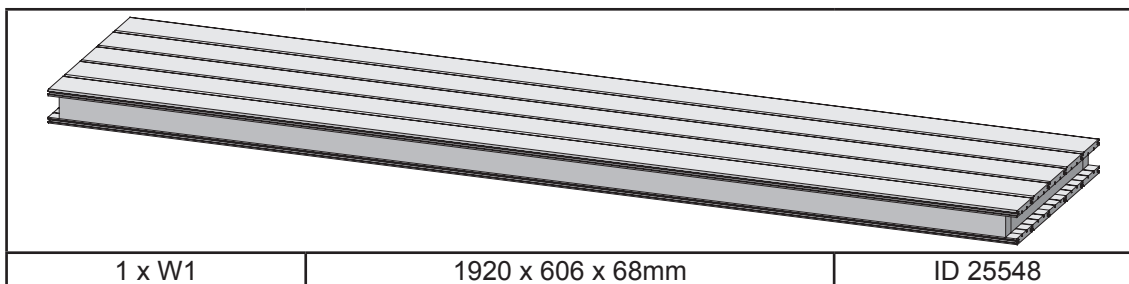

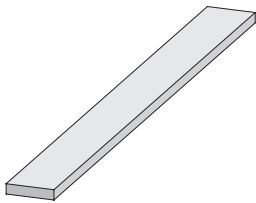

7 x B1	1920 x 19 x 3mm	ID 20799
8 x B2	70 x 30 x 4mm	ID 60343
2 x B3	750 x 36 x 12mm	ID 24239
2 x B4	1920 x 36 x 12mm	ID 24846
1 x B5	1884 x 45 x 17mm	ID 48037
1 x B6	750 x 45 x 18mm	ID 16434
4 x B7	800 x 45 x 18mm	ID 24796
4 x B8	480 x 95 x 18mm	ID 20930
2 x B9	540 x 95 x 18mm	ID 17869
4 x B10	580 x 95 x 18mm	ID 16708
2 x B11	720 x 95 x 18mm	ID 26387
1 x B12	1178 x 42 x 28mm	ID 56305
2 x B13	1232 x 42 x 28mm	ID 49465
1 x B14	1786 x 42 x 28mm	ID 59812
2 x B15	1925 x 42 x 28mm	ID 26382
2 x B16	1874 x 52 x 52mm	ID 26165

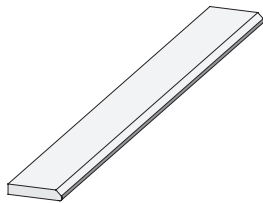

2 x E3	1884 x 45 x 17mm	ID 48521
7 x E4	1980 x 45 x 17mm	ID 48539
1 x E5	1980 x 58 x 17mm	ID 59831

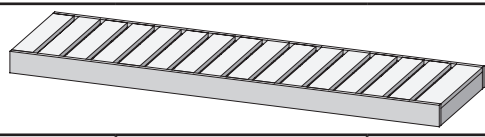

1 x L1	1730 x 500 x 90mm	ID 20567
--------	-------------------	----------

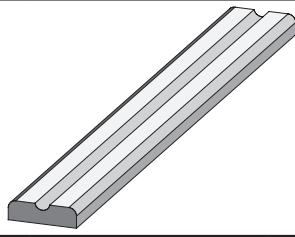

1 x L2	1730 x 90 x 22mm	ID 26388
--------	------------------	----------

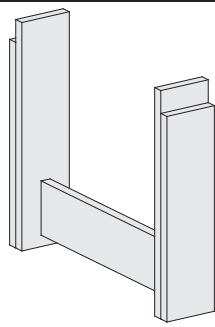

2 x L3		ID 57181
--------	--	----------

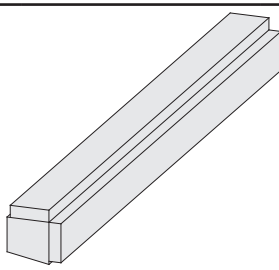

1 x K1	1874 x 64 x 64mm	ID 59817
--------	------------------	----------

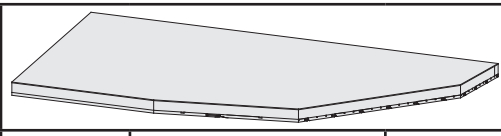

1 x M1	1839 x 918 x 57mm	ID 35142
--------	-------------------	----------

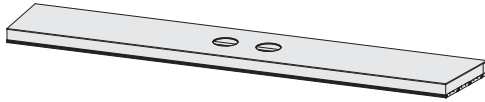

1 x M2	1785 x 303 x 57mm	ID 59830
--------	-------------------	----------

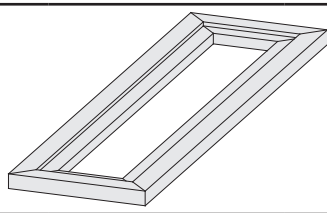

1 x N1	600 x 170 x 18mm	ID 53101
--------	------------------	----------

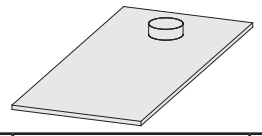

1 x N2	275 x 120 x 14mm	ID 52890
--------	------------------	----------

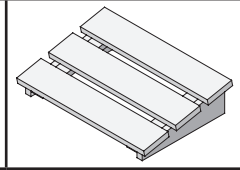

1 x		ID 25545
-----	--	----------

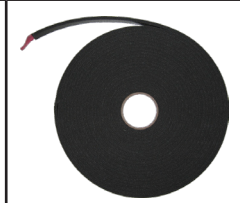

10m		ID 14025
-----	--	----------



20 x	4 x 25mm	ID 5841
40 x	4 x 30mm	ID 3686
60 x	4 x 50mm	ID 3688
50 x	4 x 70mm	ID 3689
50 x	4,5 x 80mm	ID 9204
20 x	6 x 60mm	ID 14014



120 x	4,5 x 40mm	ID 26285
-------	------------	----------

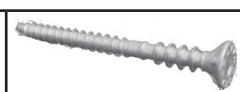

6 x S1		ID 14266
--------	--	----------



120 x S2	4,5 x 30mm	ID 26116
6 x S3	12 x 18mm	ID 46403



20 x		ID 14005
------	--	----------

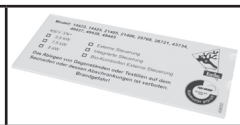

1 x		ID 49867
-----	--	----------

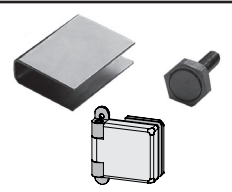

2 x		ID 26496
-----	--	----------

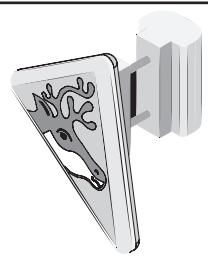

1 x		ID 26114
-----	--	----------

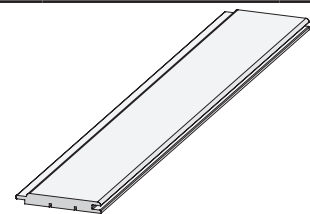

1 x E1	1920 x 97 x 12mm	ID 22863
--------	------------------	----------

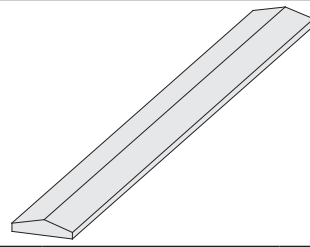

1 x E2	1884 x 45 x 17mm	ID 48538
--------	------------------	----------

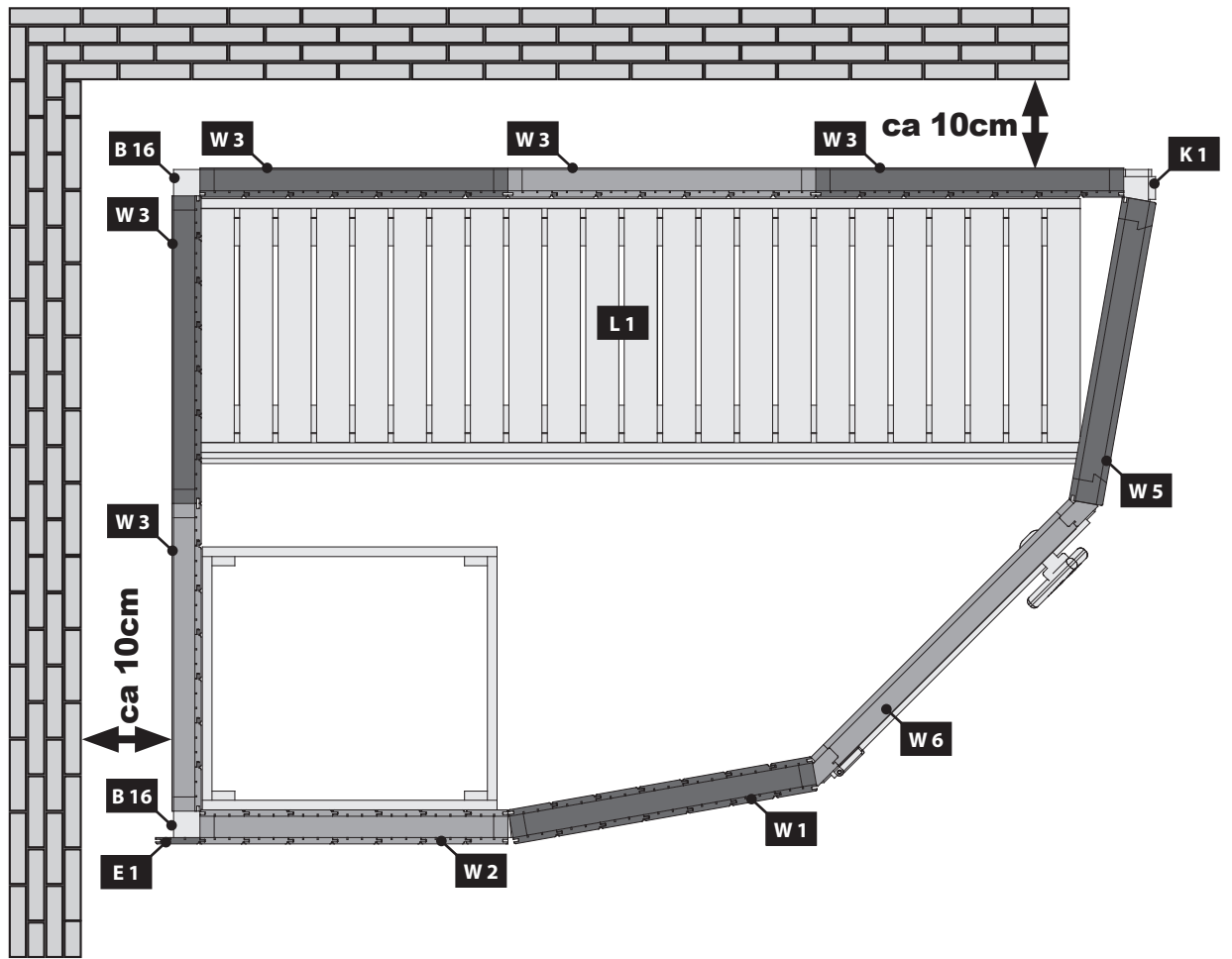

**01** 2x

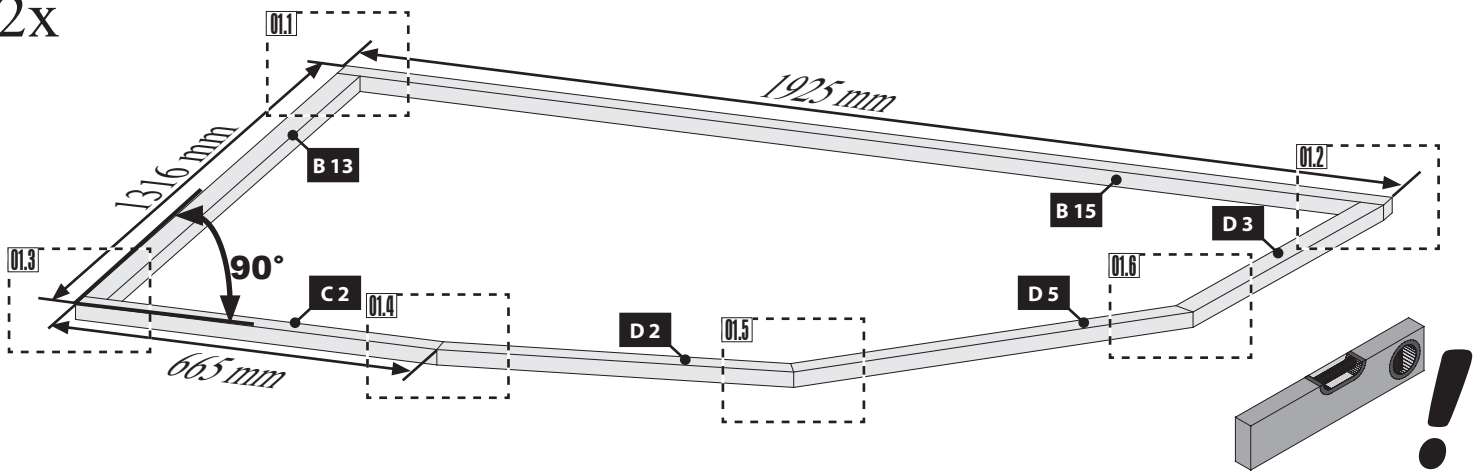

**01.1**

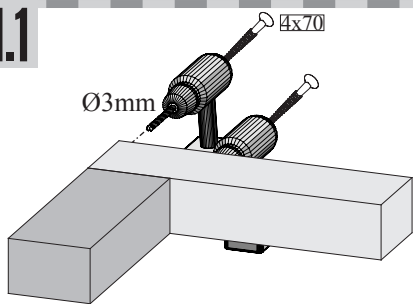

**01.2**

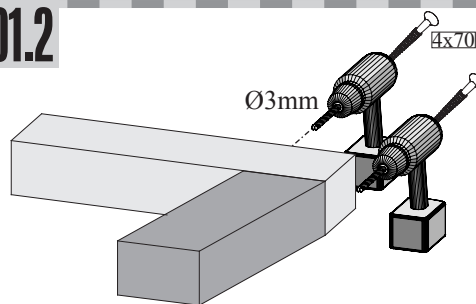

**01.3**

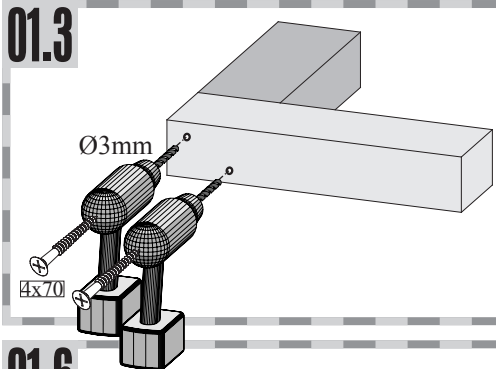

**01.4**

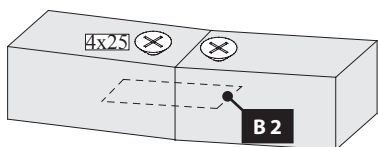

**01.5**

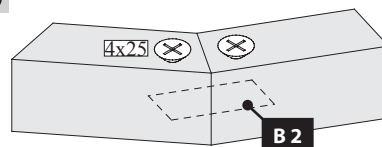

**01.6**

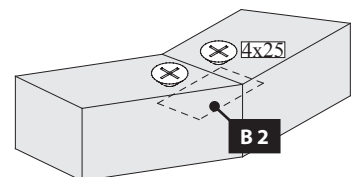

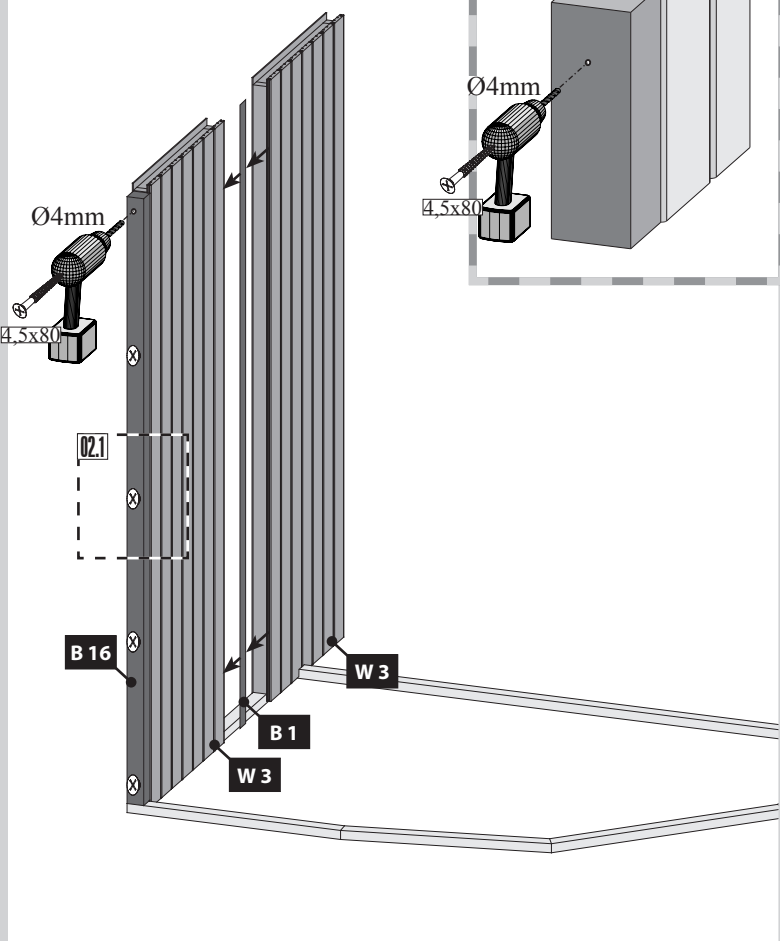
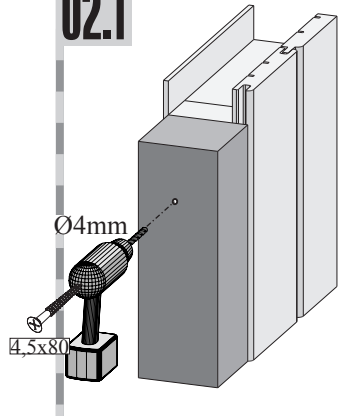
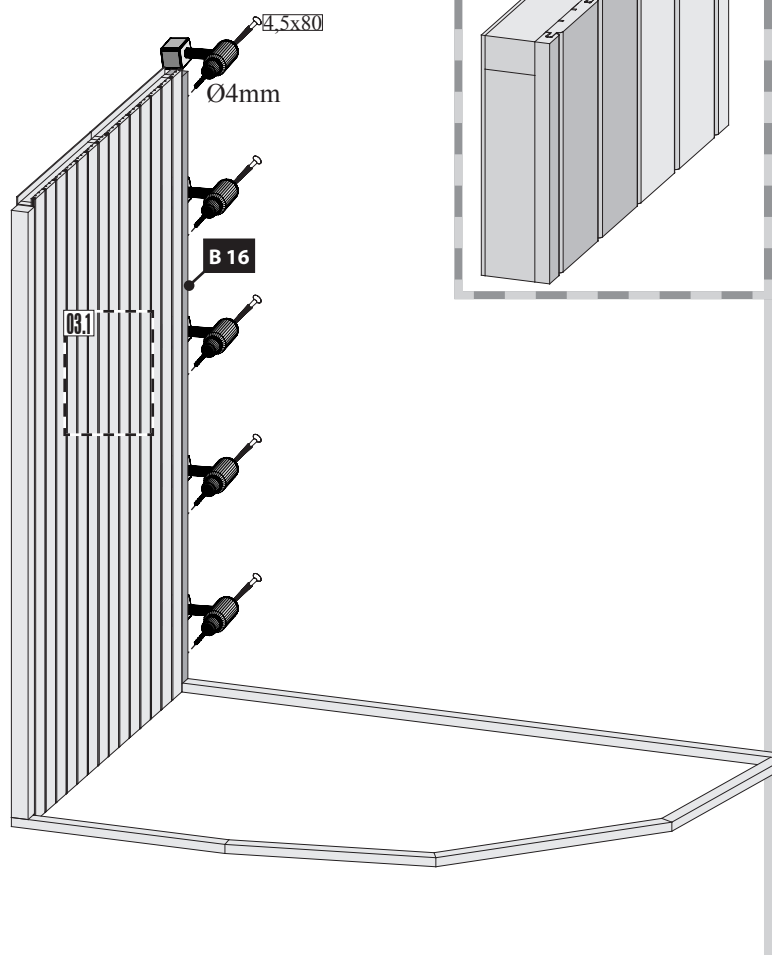
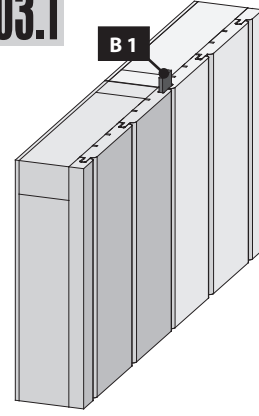
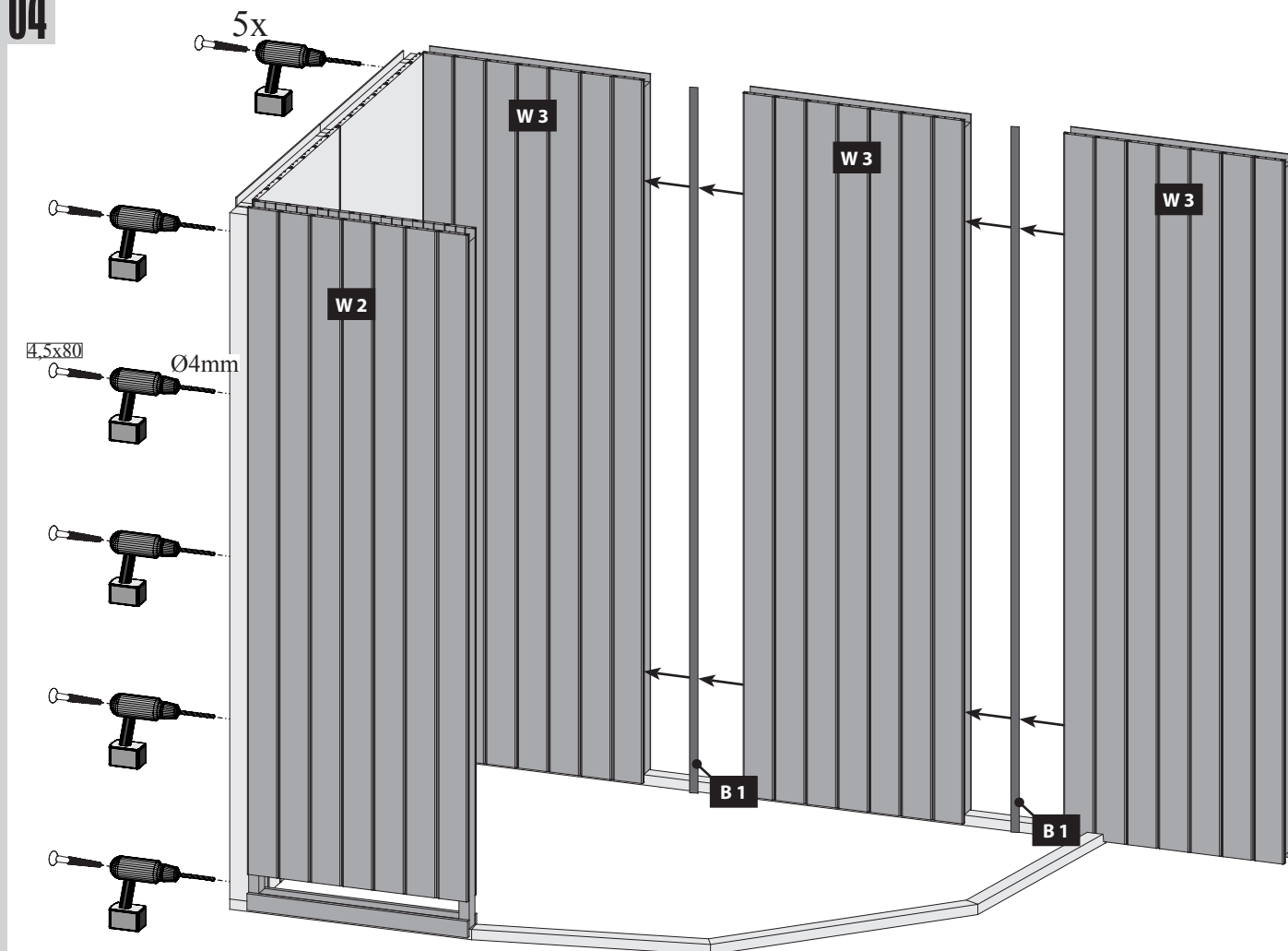

**02****02.1****03****03.1****04**

05

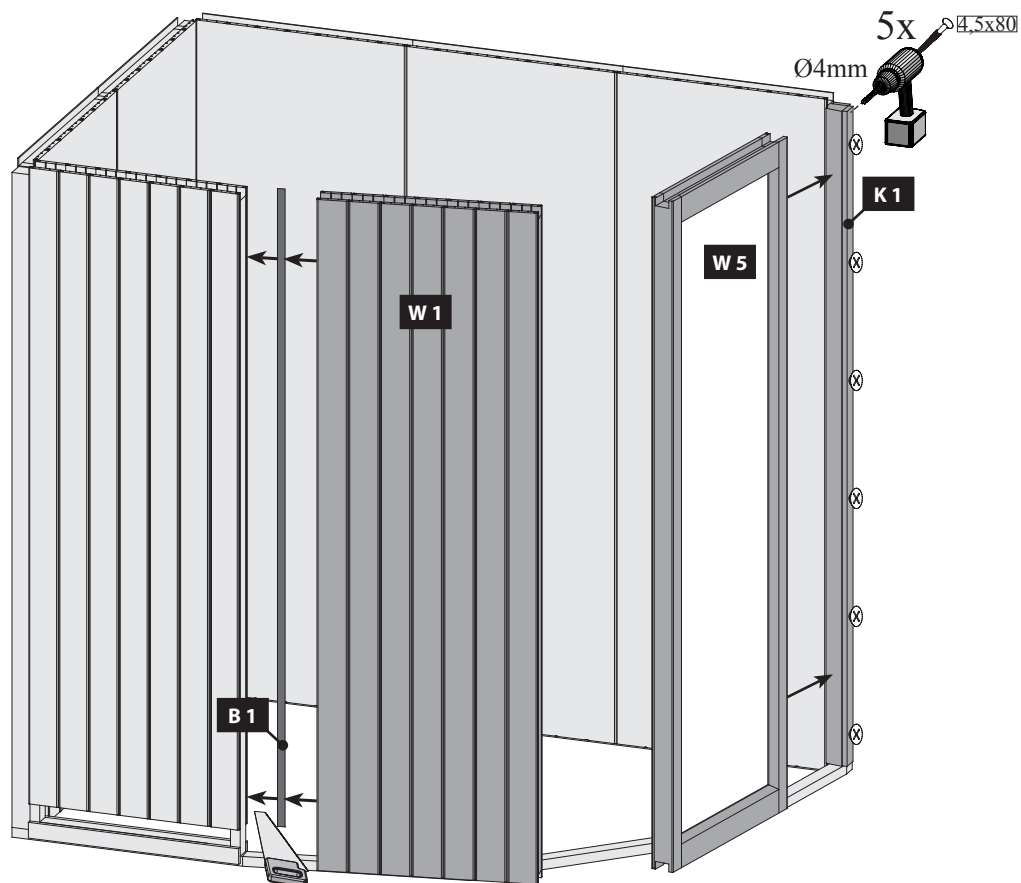

06

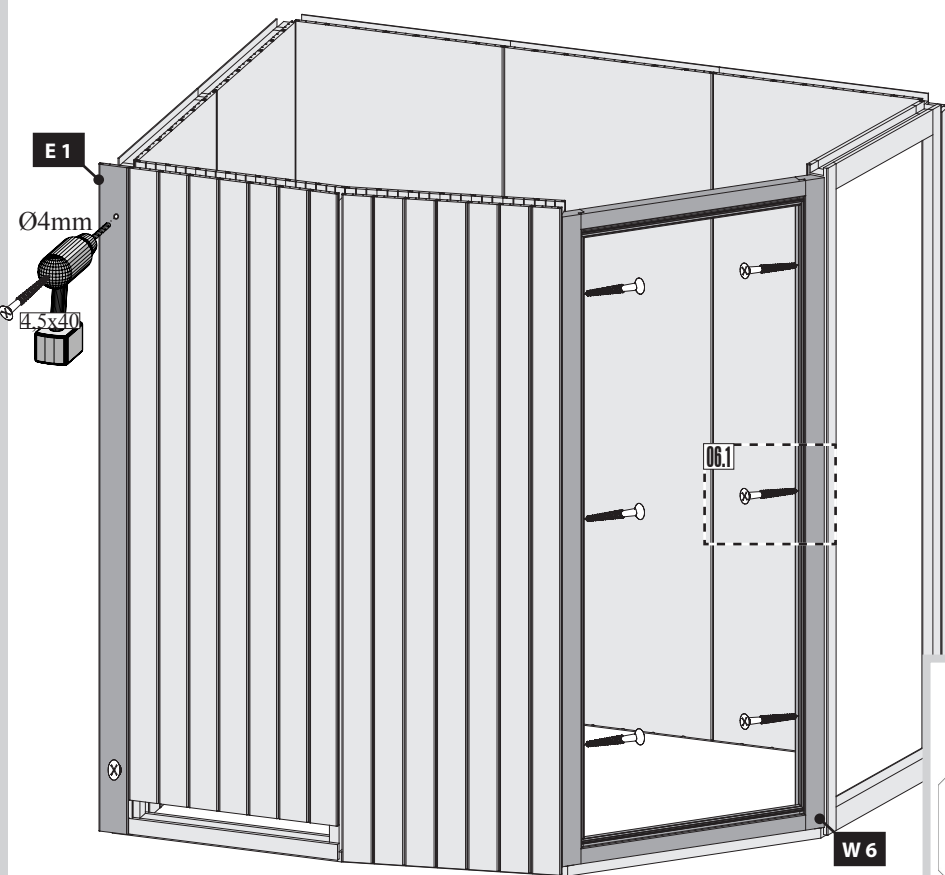

06.1-1

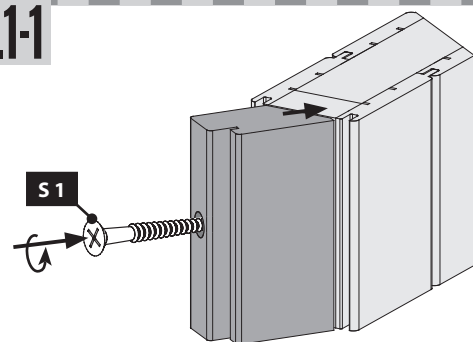

06.1-2

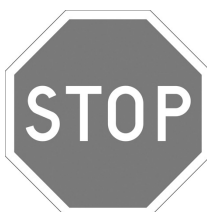
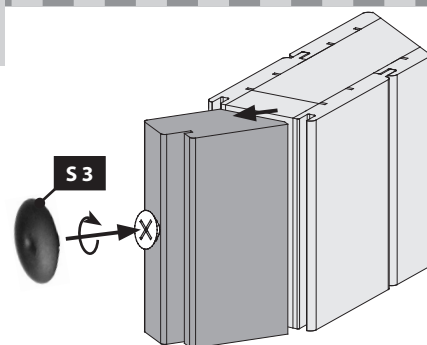

- Einbau Glastür
- Montage porte en verre
- Installation of glass door
- Montage van de glazen deur
- Montaje de la puerta de cristal
- Installazione portello di vetro

**!!!** 01 — 03 **!!!**

07

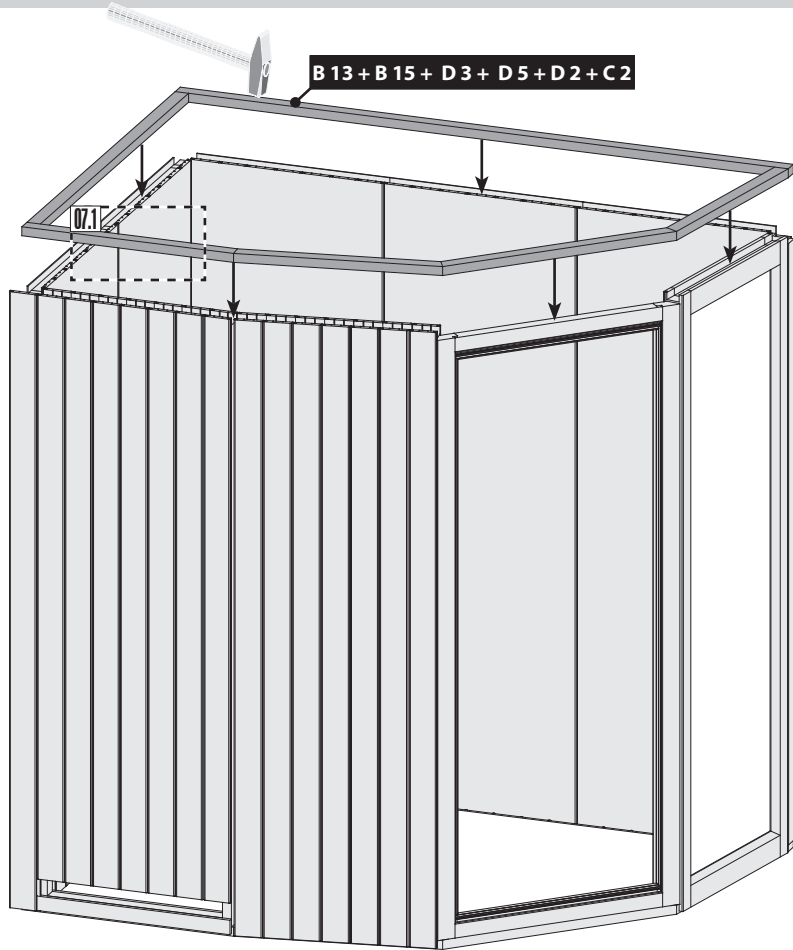

08

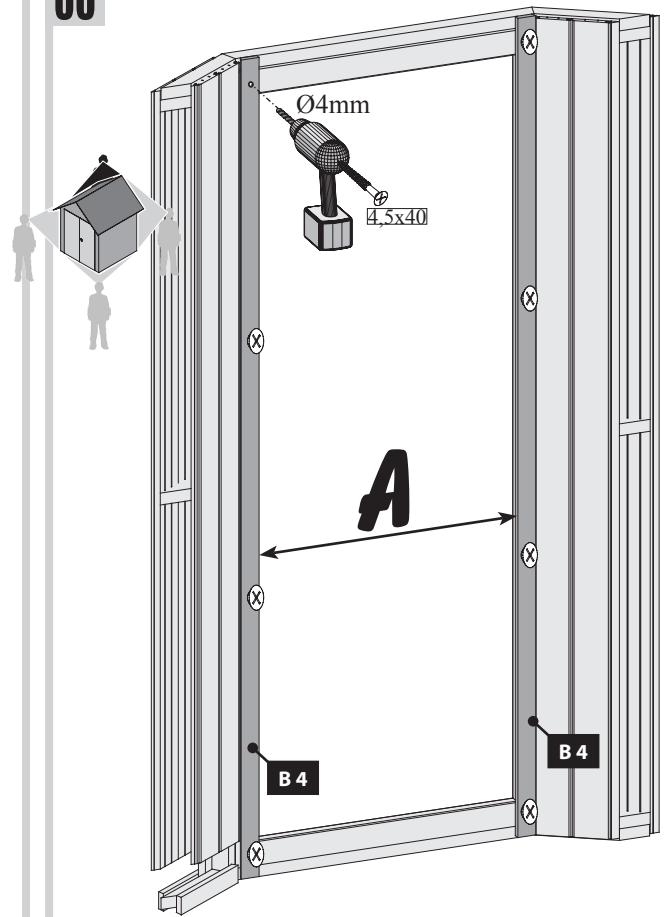

07.1

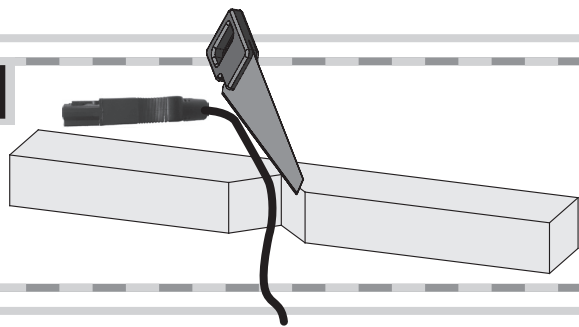

09 2x

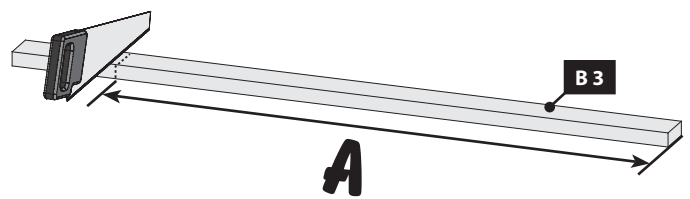

10

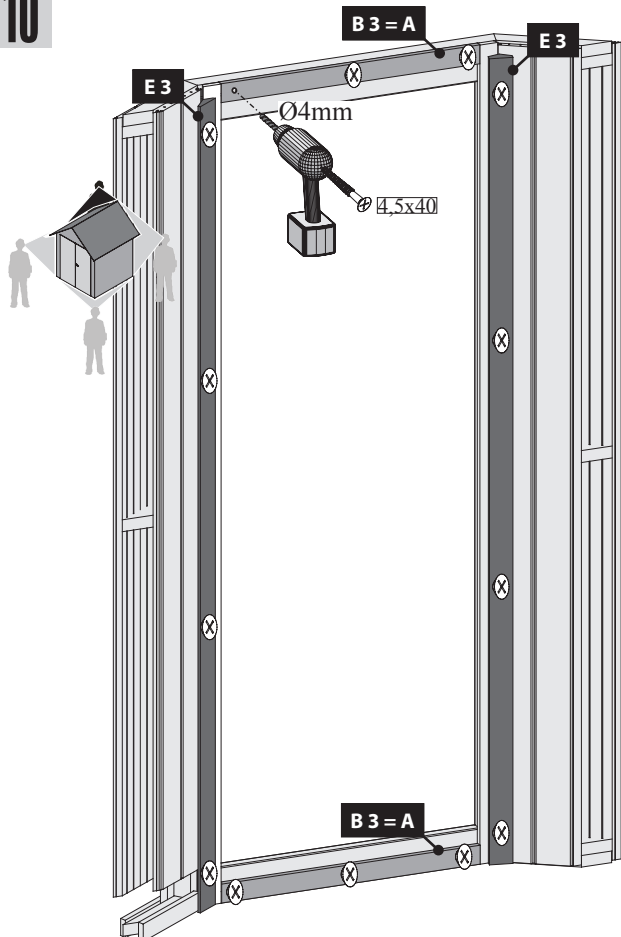

11

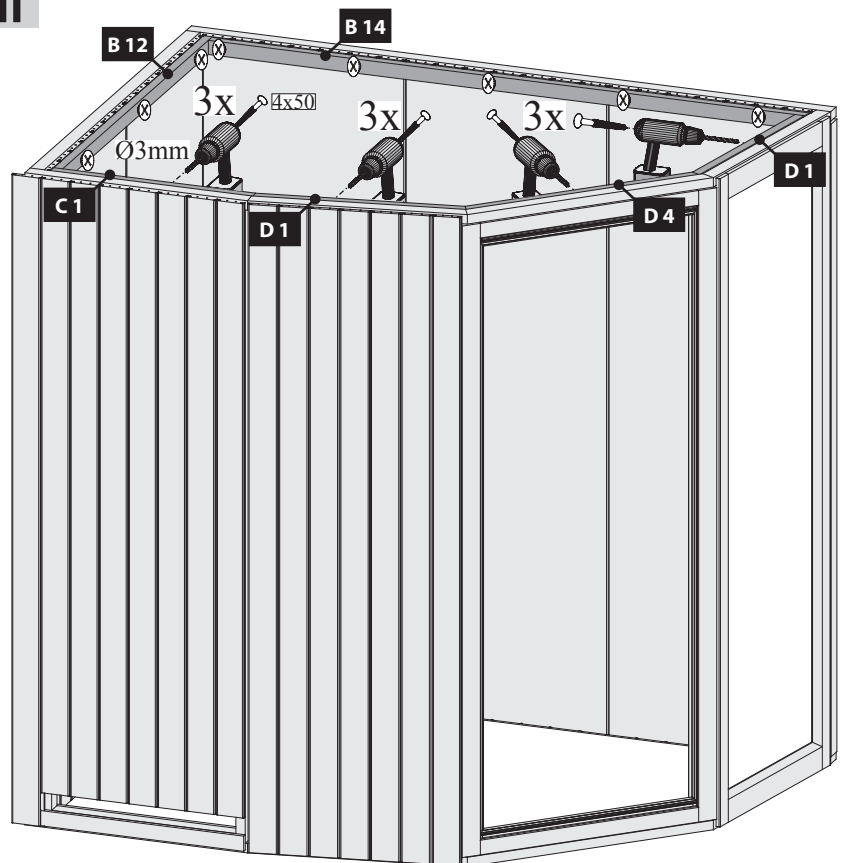

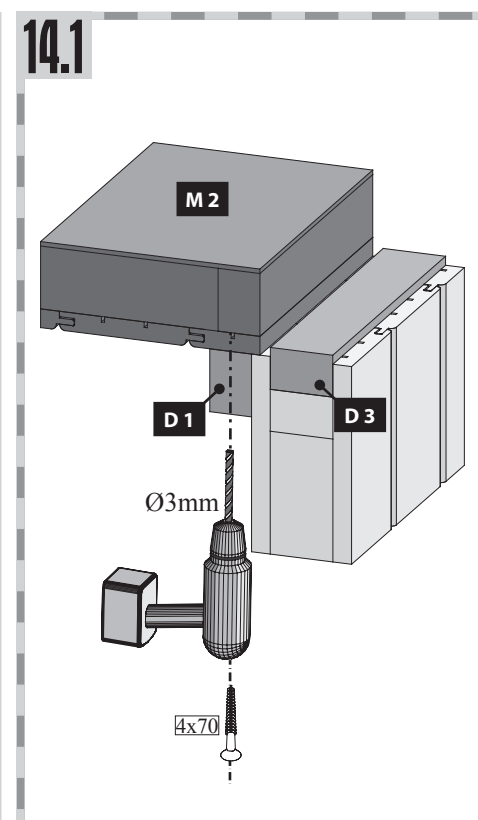
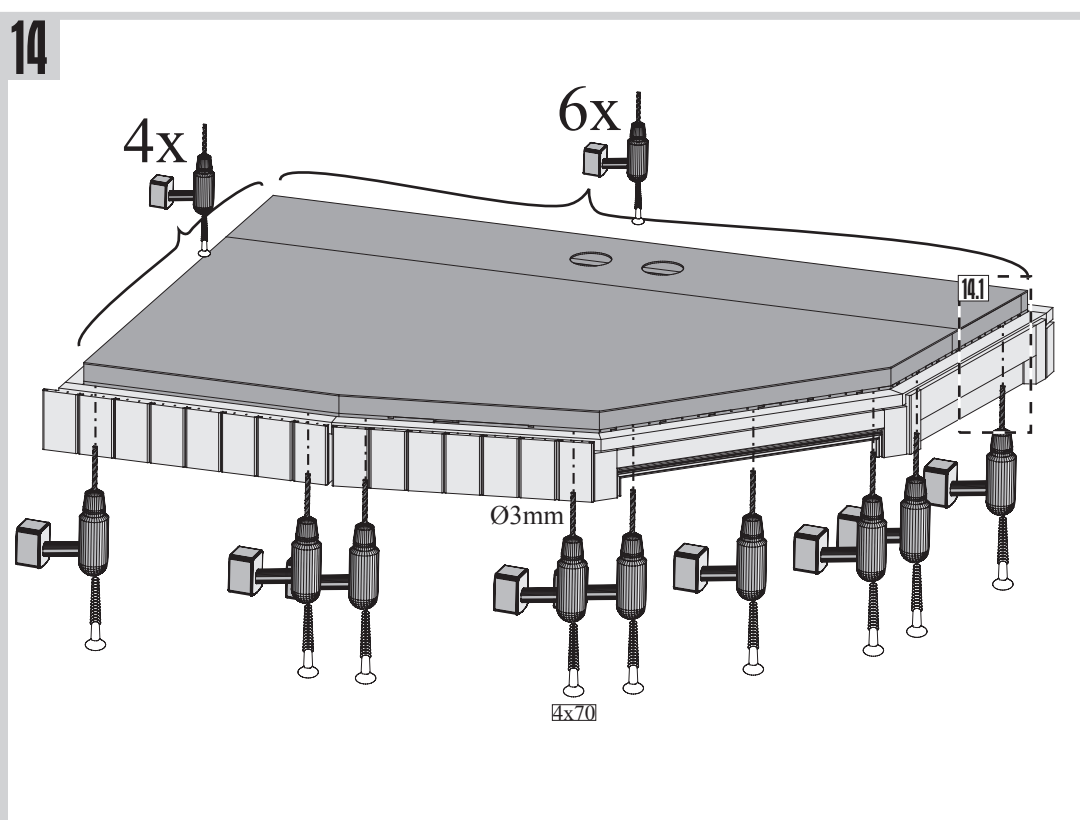
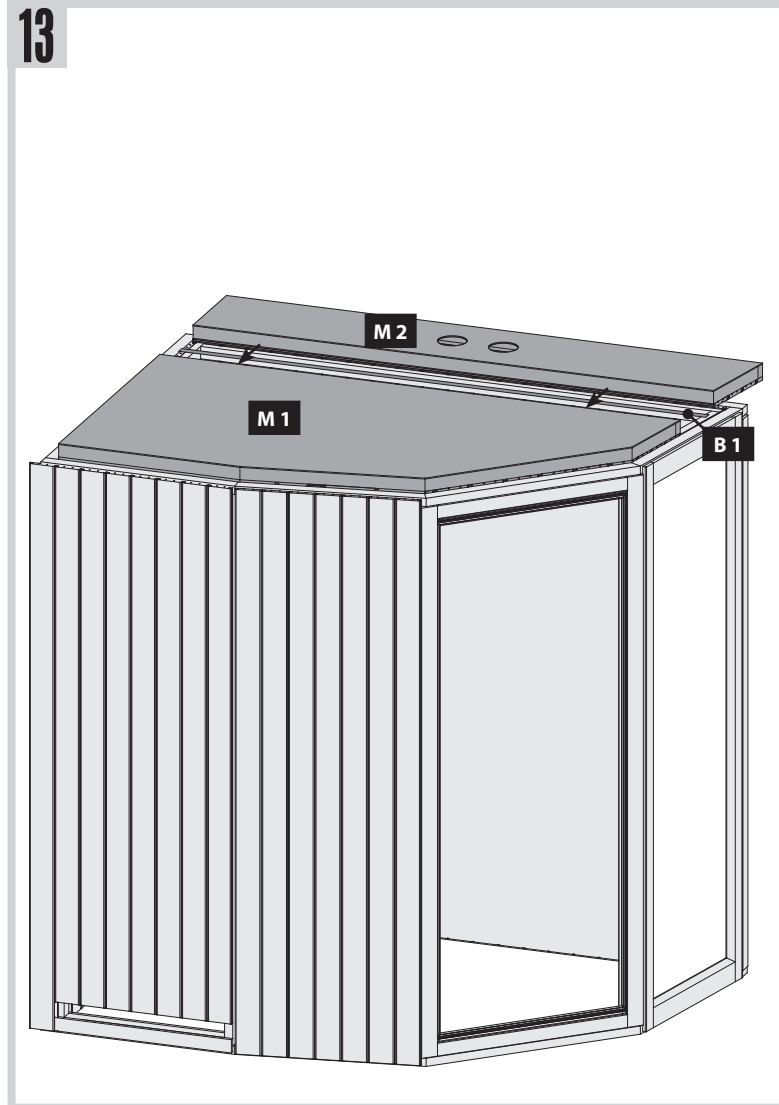
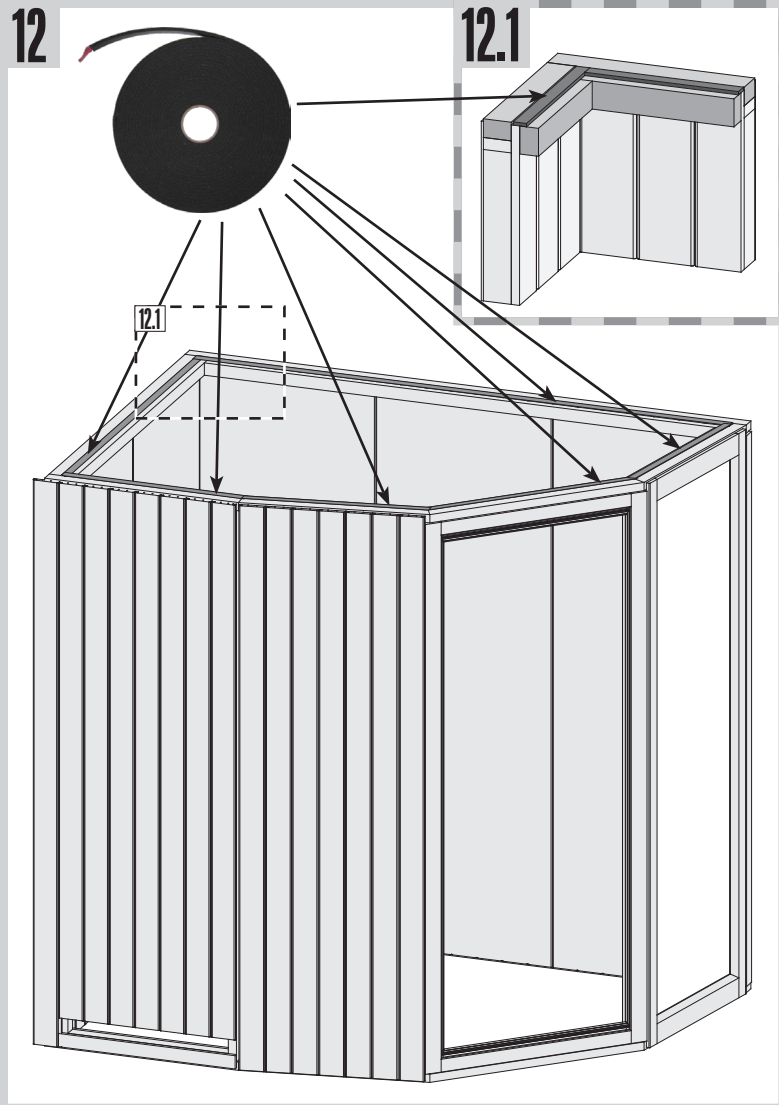

15

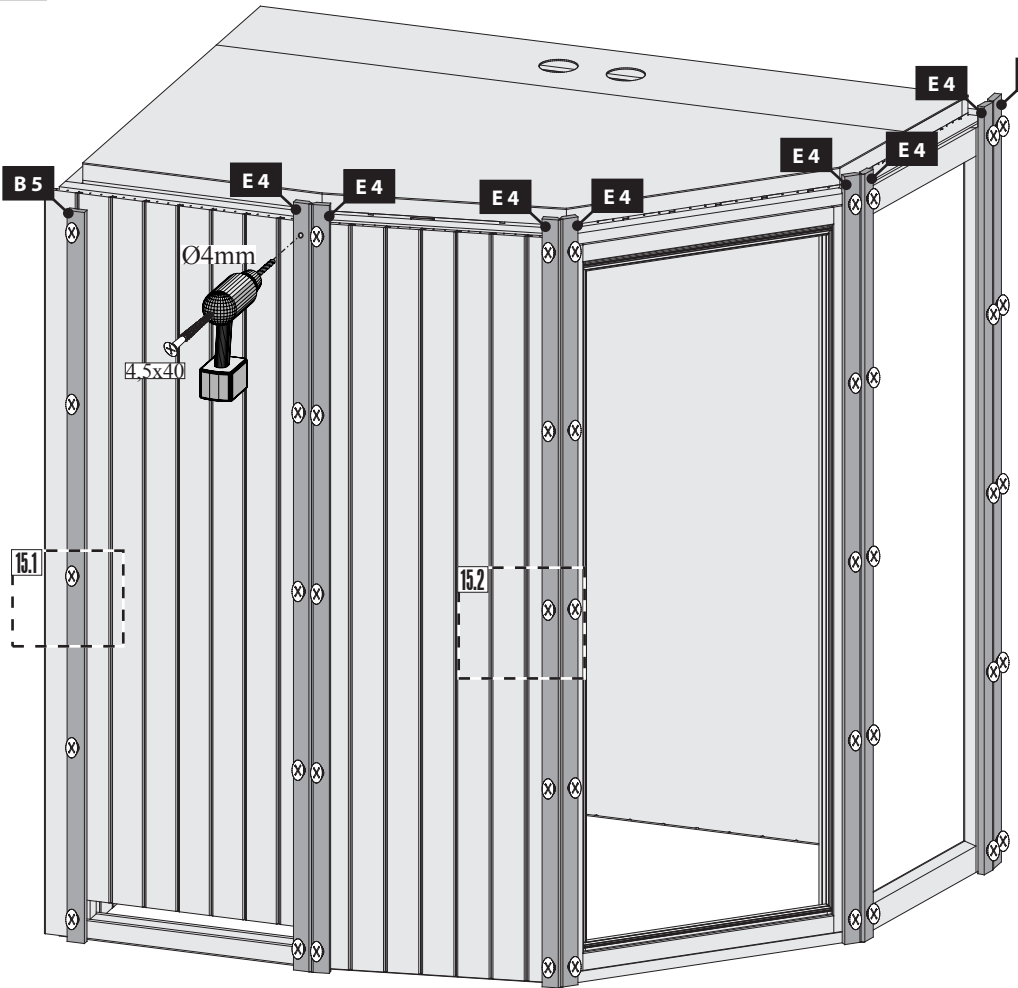

15.1

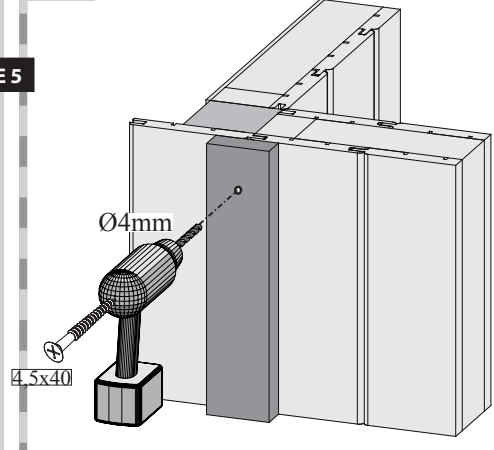

15.2

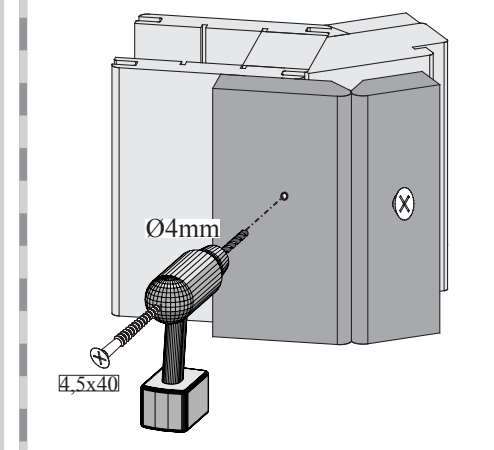

16

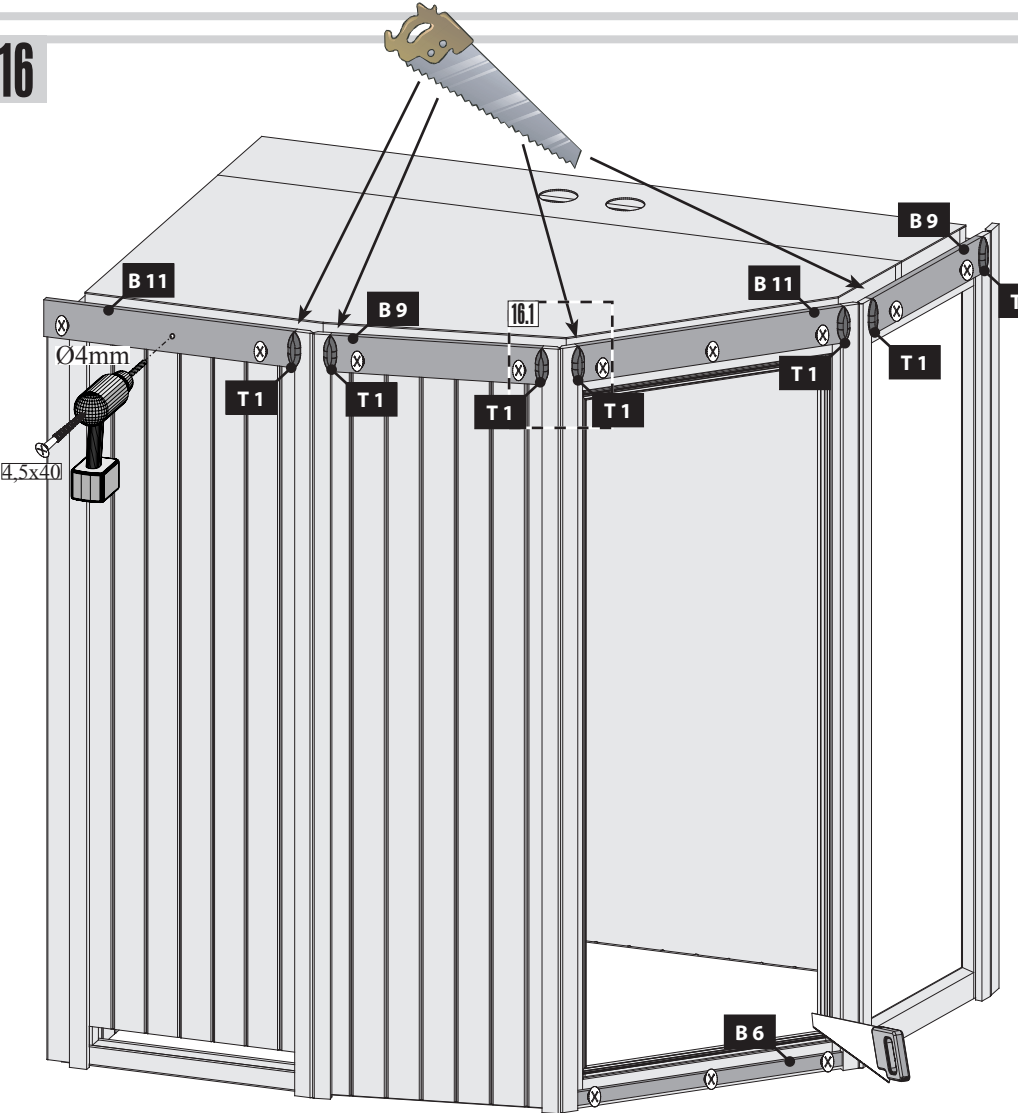

16.1

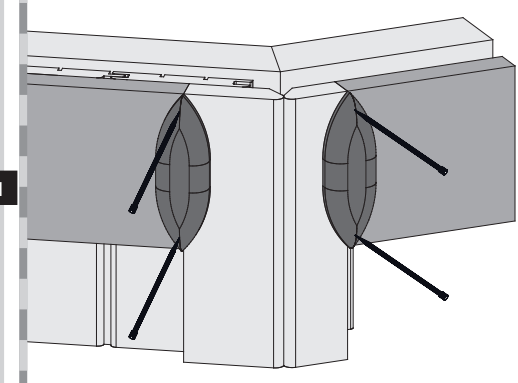

17



18

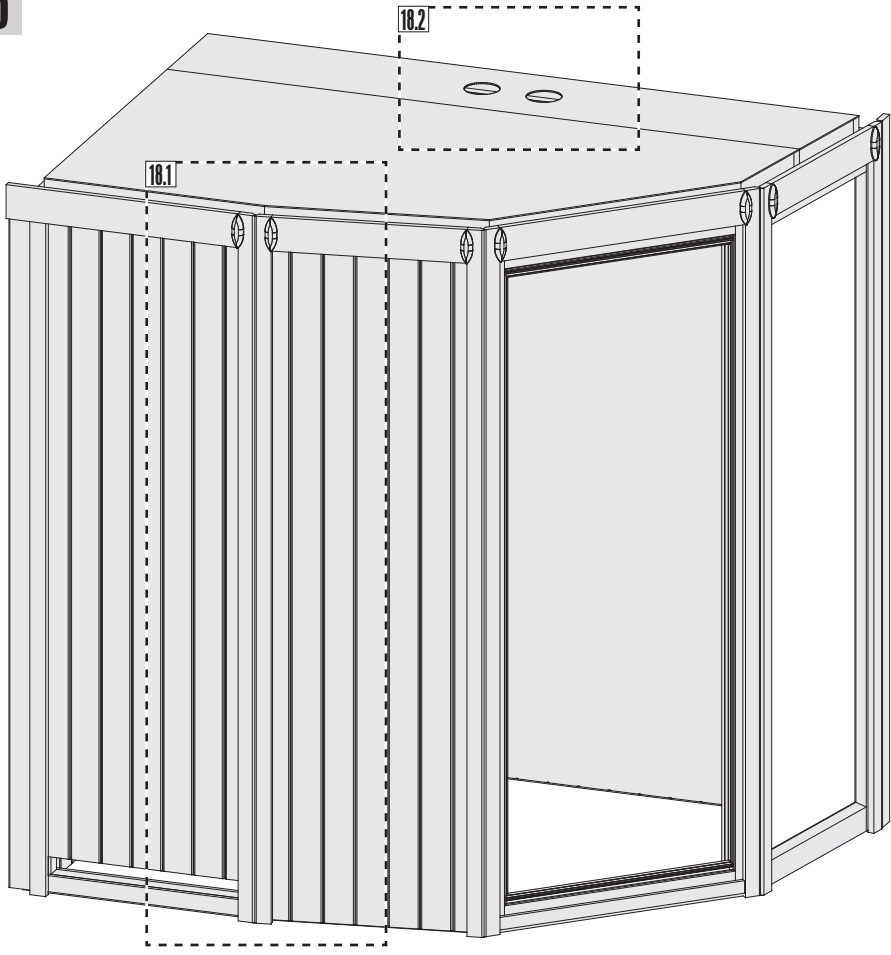

18.1

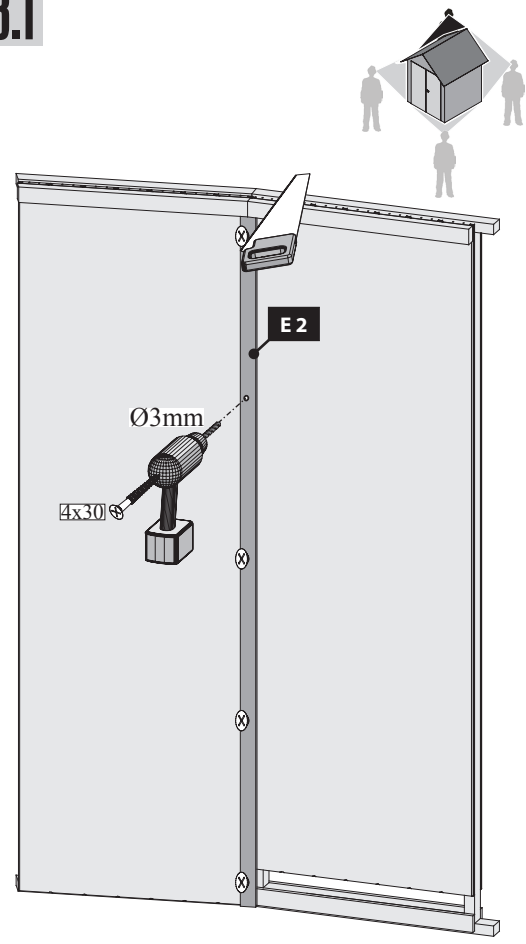

18.2-1

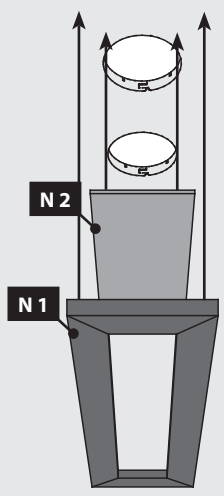

19

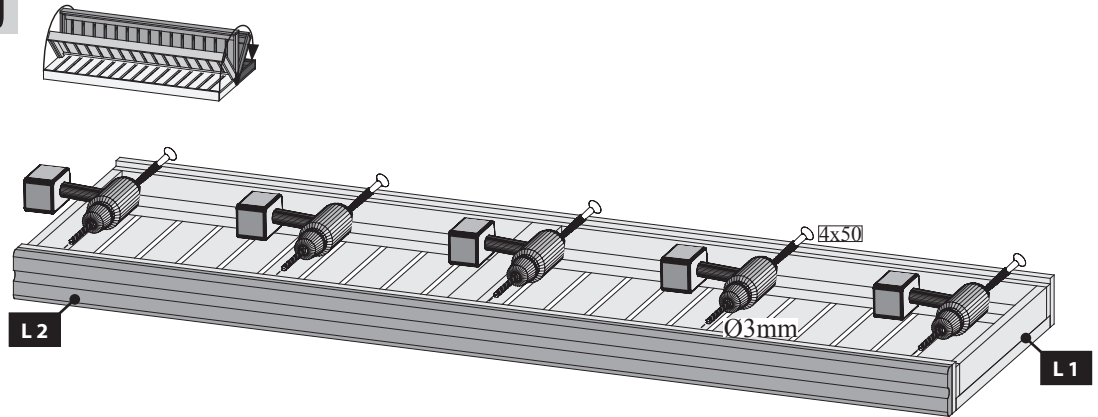

18.2-2

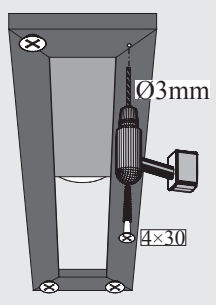

20

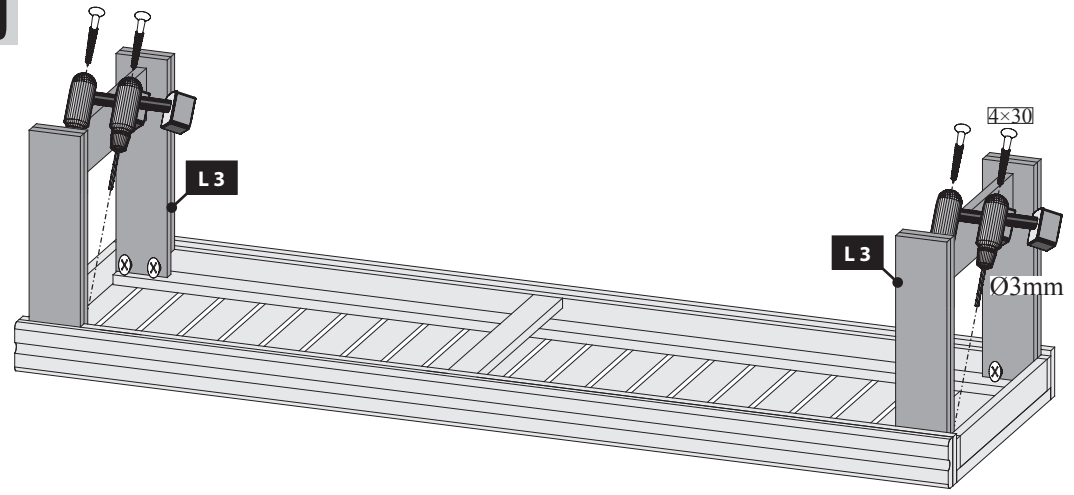

21 2x

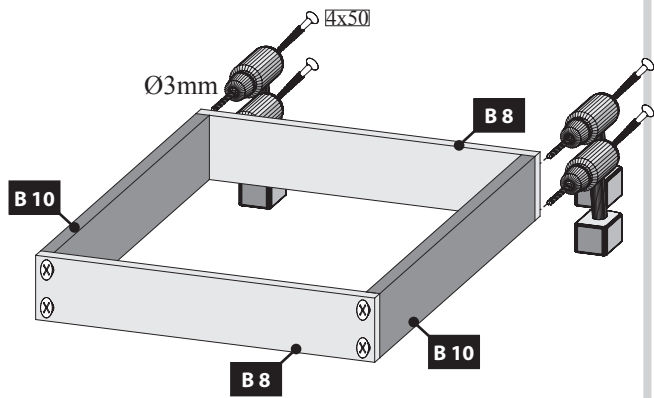

22

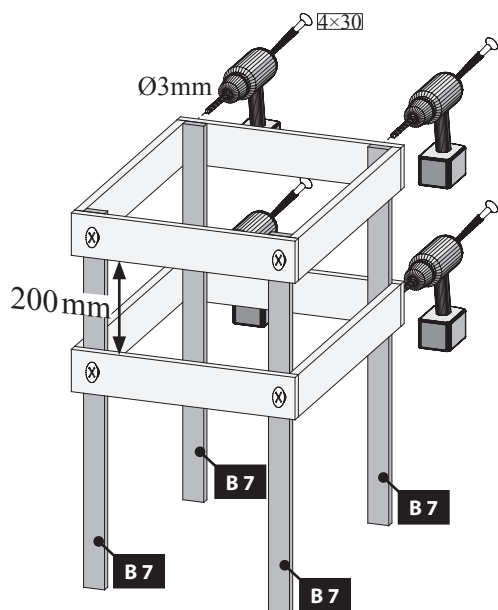



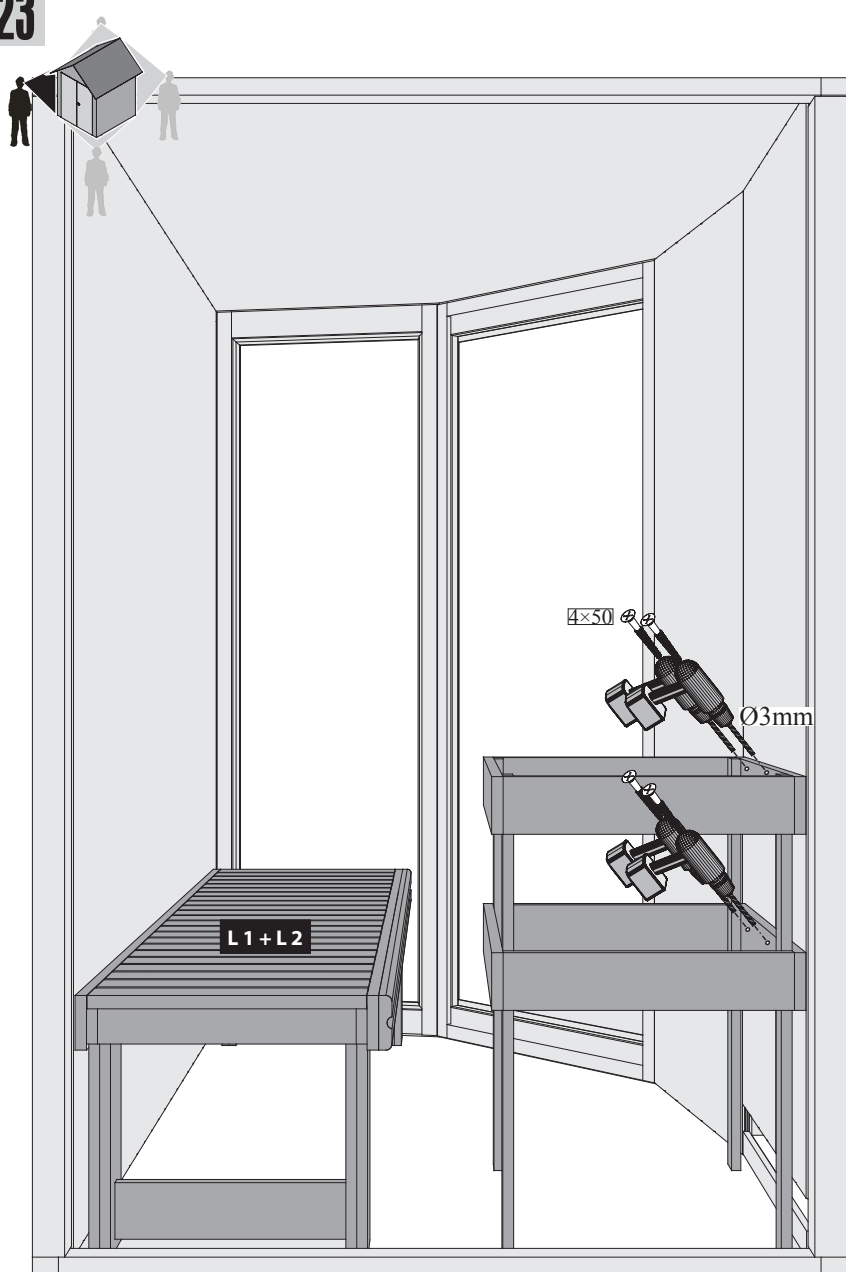

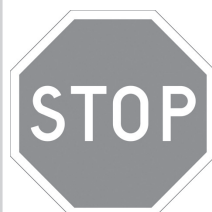
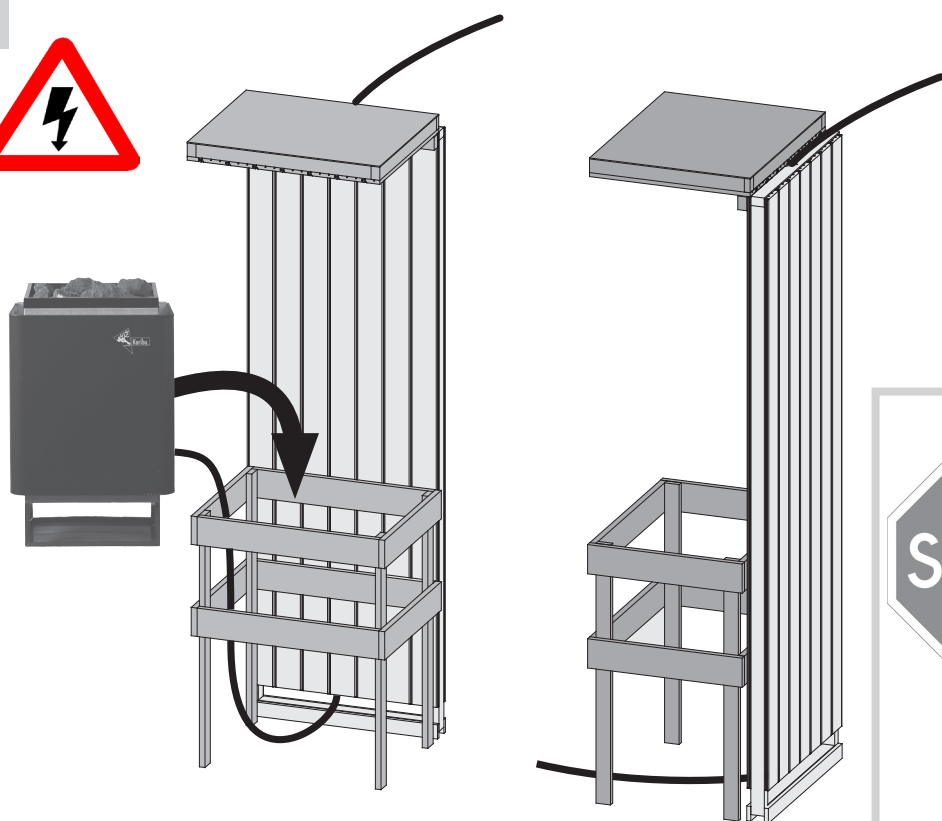

23



24



-  Einbau Glastür
-  Montage porte en verre
-  Installation of glass door
-  Montage van de glazen deur
-  Montaje de la puerta de cristal
-  Installazione portello di vetro

**!!!** 04 — 08 **!!!**



 Einbau Glastür

 Installation of glass door

 Montaje de la puerta de cristal

 Montage porte en verre

 Montage van de glazen deur

 Installazione portello di vetro

01

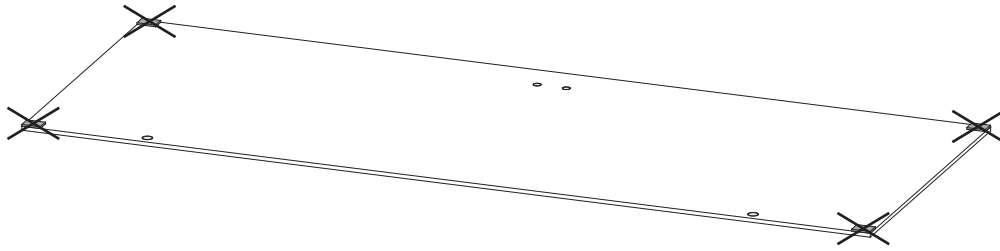

02

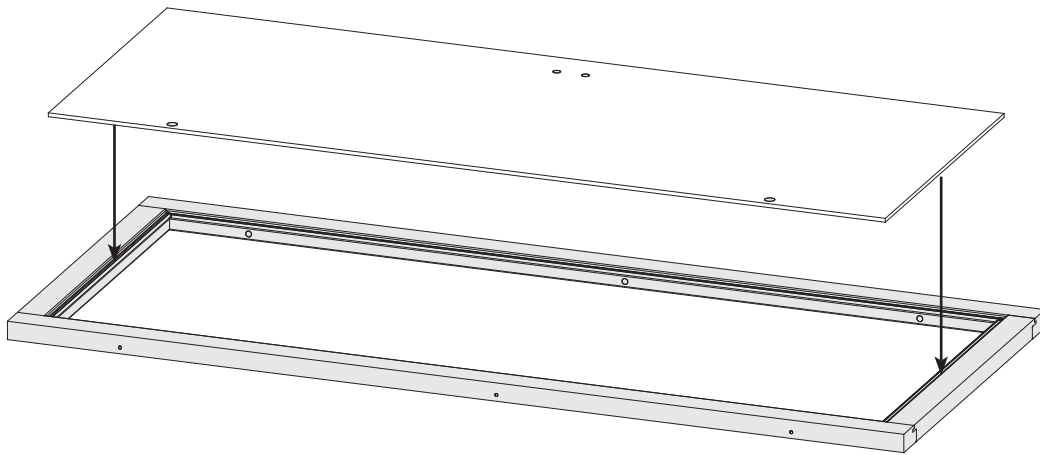



03

 Das Saunätürglas im Türrahmen ausrichten!

 Bien aligner le verre à vitre!

 To start building up the door you need to center the glass in the wooden frame!

 Plaats het glas van de sauna deur in het midden van het kozijn!

 ¡Centrar la puerta de cristal dentro del marco!

 Allineare il vetro dello sportello sauna al telaio della porta!

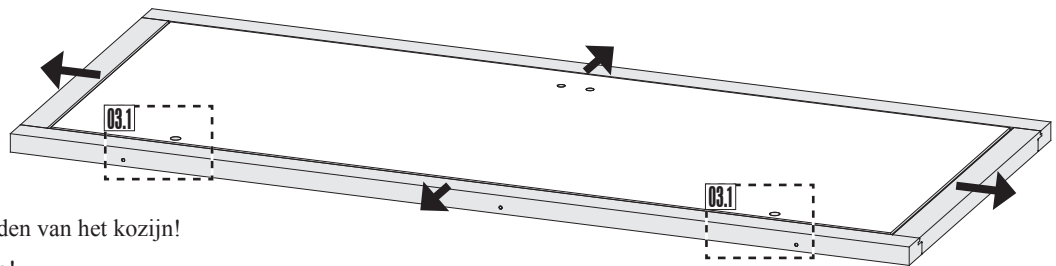

03.1-1

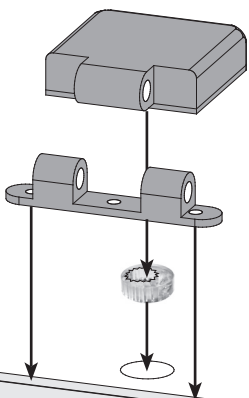

03.1-2

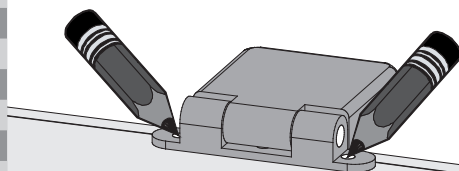

03.1-3

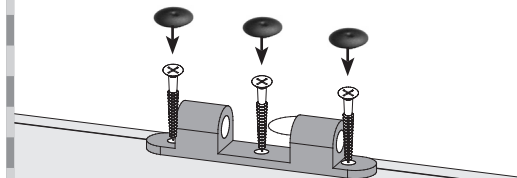

 Einbau Glastür

 Installation of glass door

 Montaje de la puerta de cristal

 Montage porte en verre

 Montage van de glazen deur

 Installazione portello di vetro

04

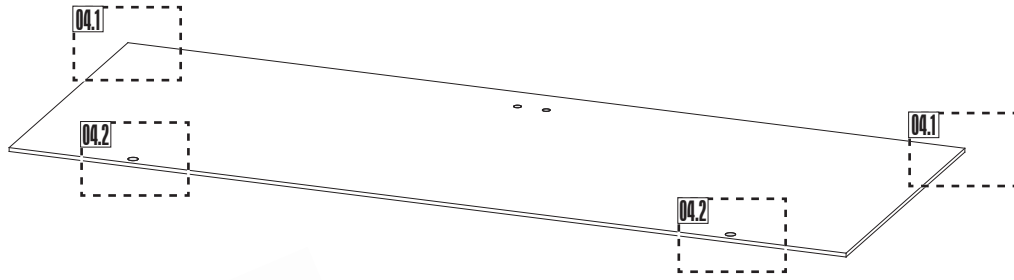

04.1-1

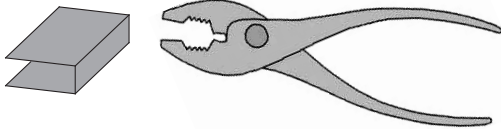

04.1-2

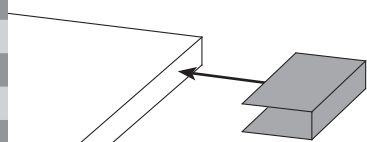

04.1-3

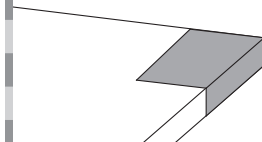

04.2-1

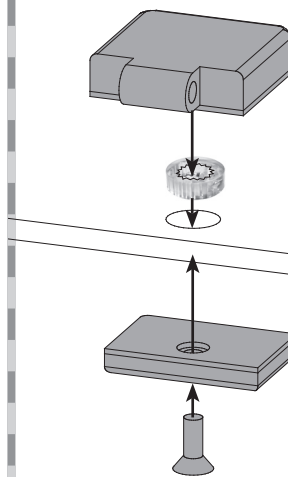

04.2-2

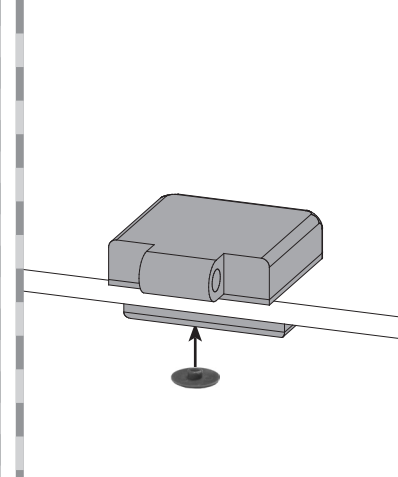

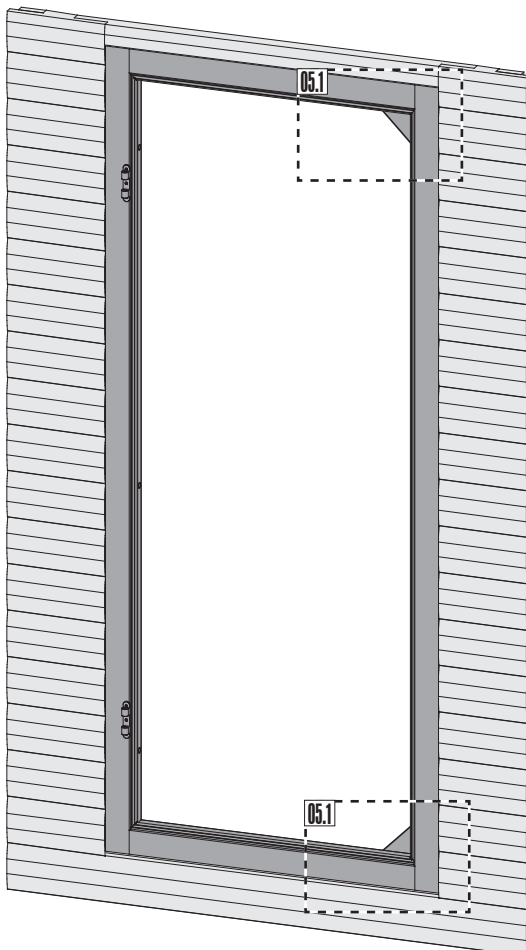

05





 Achtung: Alle Verstell-Excenter müssen in der Glasscheibe die gleiche Grundstellung haben!

 Attention: Tous les excentres de positionnement doivent avoir la même position de base dans la vitre!

 Attention: All adjustable eccentrics must have the same basic adjustment in the glass pane!

 Attentie: alle excentrische verstelelementen moeten in dezelfde stand in de glasplaat worden geplaatst!

 Atención: Todos los excéntricos regulables tienen que tener la misma posición base en la hoja de cristal.

 Attenzione: Tutti gli eccentrici di regolazione devono avere la stessa posizione base nella lastra di vetro!

05.1-1



05.1-2



 Einbau Glastür

 Installation of glass door

 Montaje de la puerta de cristal

 Montage porte en verre

 Montage van de glazen deur

 Installazione portello di vetro

06

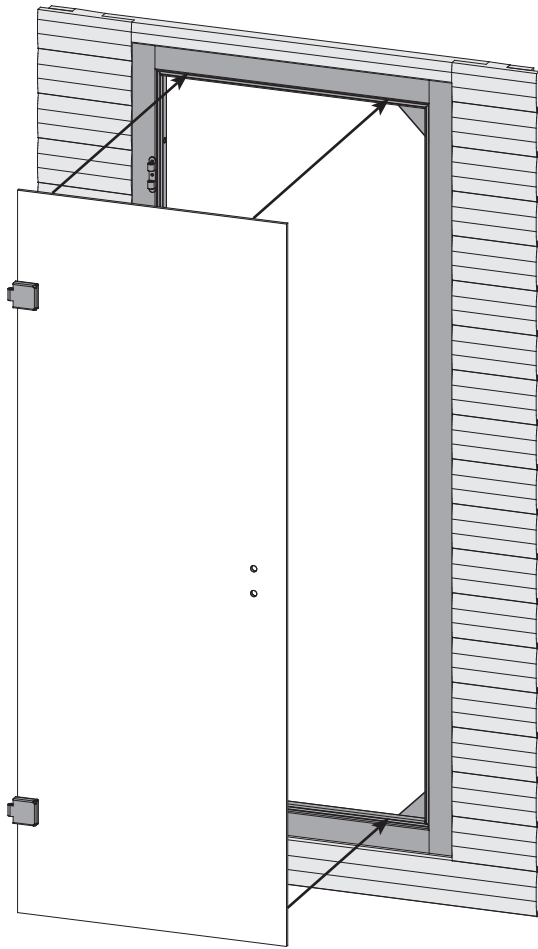

07

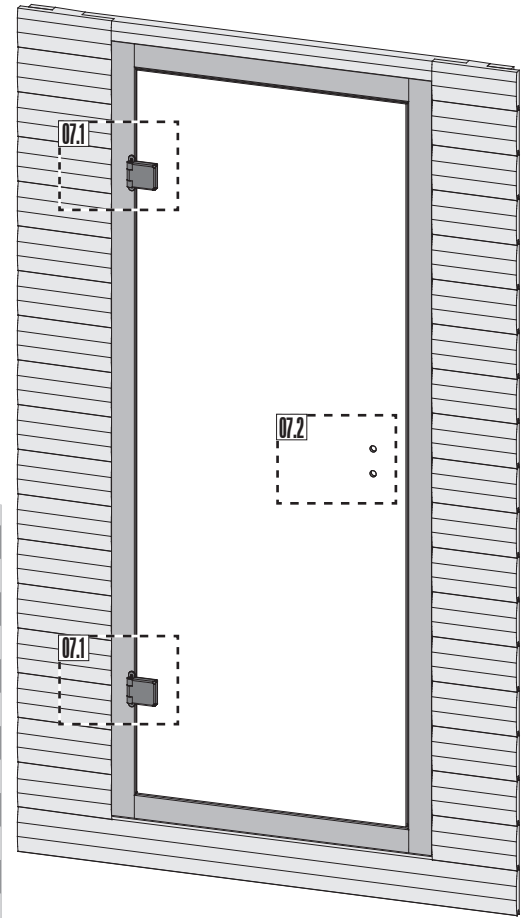

07.1

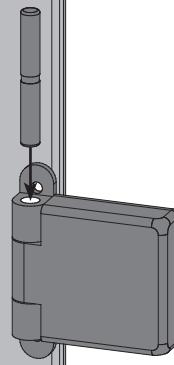

07.2-1

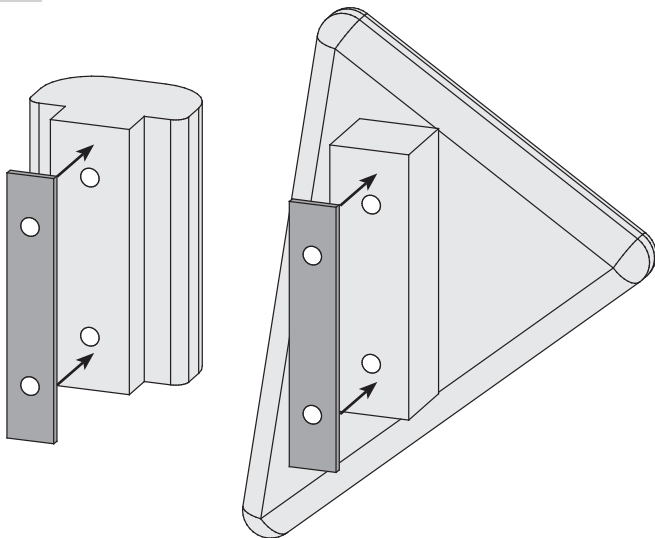

07.2-2

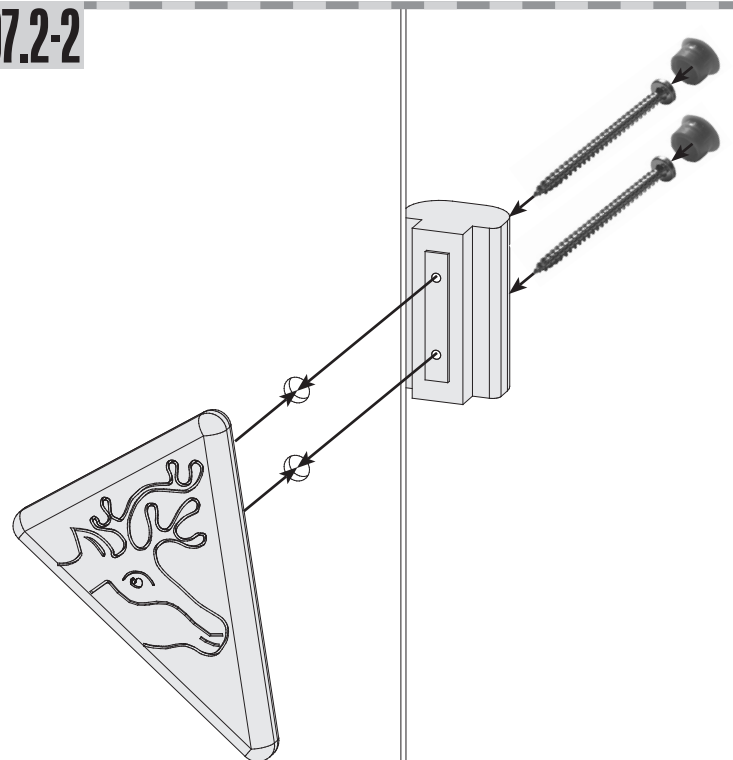

 **Seitenverstellung + Höhenverstellung**

Achtung: Alle Verstell-Excenter müssen in der Glasscheibe die gleiche Grundstellung haben!

 **Positionnement latéral + positionnement hauteur**

Attention: Tous les excentres de positionnement doivent avoir la même position de base dans la vitre!

 **Lateral adjustment + height adjustment**

Attention: All adjustable eccentrics must have the same basic adjustment in the glass panel!

 **Zijverstelling + hoogteverstelling**

Attentie: alle excentrische verstelelementen moeten in dezelfde stand in de glasplaat worden geplaatst!

 **Regulación lateral + regulación de la altura**

Atención: Todos los excéntricos regulables tienen que tener la misma posición base en la hoja de cristal.

 **Regolazione laterale + regolazione dell'altezza**

Attenzione: Tutti gli eccentrici di regolazione devono avere la stessa posizione base nella lastra di vetro!

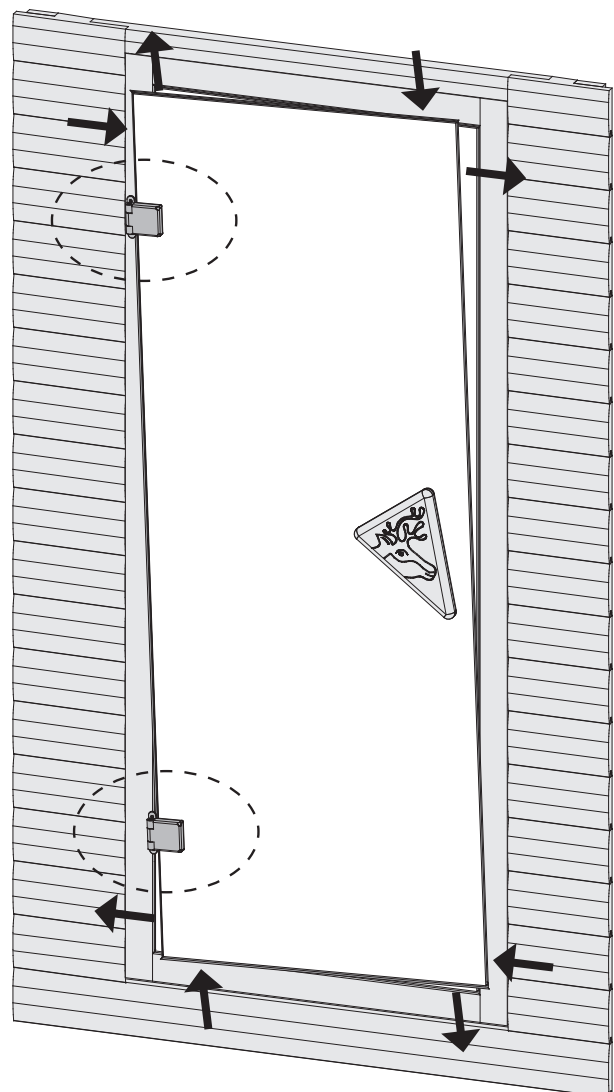
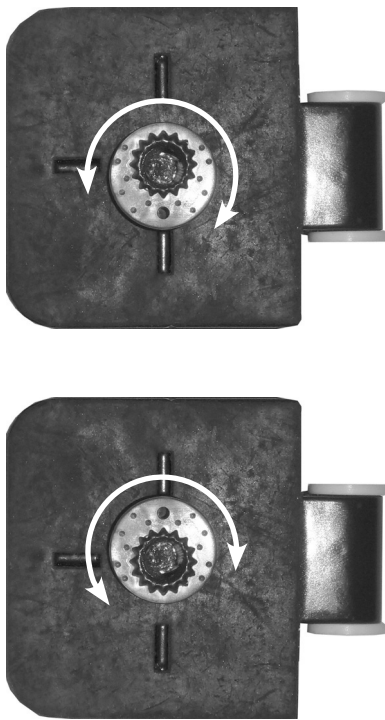

01

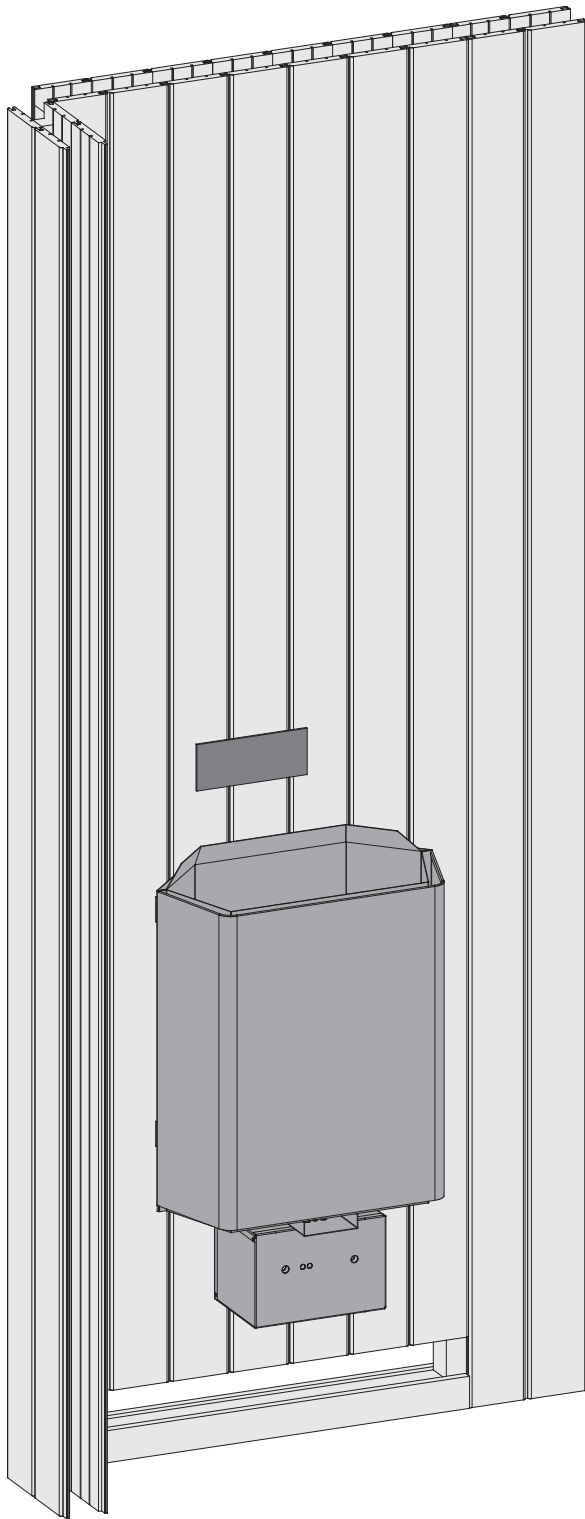

02

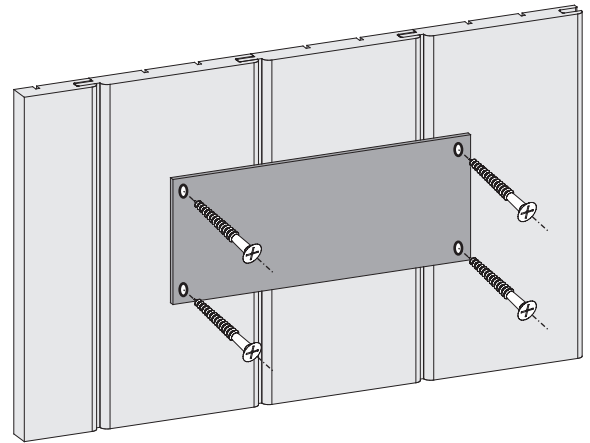

Entfernen Sie die Schutzfolie vom beiliegenden TÜV-Schild.

Lassen Sie den Saunaofen von einem zugelassenen Elektrofachmann anschließen. Dieser markiert den installierten Ofen auf dem TÜV-Schild.

Bringen Sie das TÜV-Schild an einer gut sichtbaren Stelle über dem Ofen an.

